

## (IES-)SFP+LX-10(20)

SFP 10Gb/s 1310nm Single-mode 10(20)km DDM

### PRODUCT FEATURES

- · Up to 11.3Gb/s Data Links
- · 1310nm DFB laser transmitter and PIN/TIA receiver
- · Up to 10km/20km on 9/125μm SMF
- · Hot-pluggable SFP footprint
- · Duplex LC/UPC type pluggable optical interface
- · Maximum power consumption 1 Watts
- · Metal enclosure, for lower EMI
- · Support Digital Diagnostic Monitor interface
- · Single +3.3V power supply
- · Case operating temperature:  
 Commercial: 0°C to +70°C  
 Industrial: -40°C to +85°C

### APPLICATIONS

- · 10G Ethernet 10GBASE-LR/LW

### COMPLIANCE

- SFP MSA
- SFF-8431 and SFF-8432
- SFF-8472
- RoHS 2.0
- IEEE802.3ae

### Ordering information

Part Number	Data Rate (Gb/s)	Media	Wavelength(nm)	Operating distance(km)	Temperature(°C)
SFP+LX-10	10.3125	SMF	1310	10	0~70
IES-SFP+LX-10	10.3125	SMF	1310	10	-40~85
SFP+LX-20	10.3125	SMF	1310	20	0~70
IES-SFP+LX-20	10.3125	SMF	1310	20	-40~85

## PRODUCT DESCRIPTION

(IES-)SFP+LX-10(20) SFP+ transceivers are compatible with the Small Form Factor Pluggable Multi-Sourcing Agreement (MSA). The module data link up to 10km/20km in 9/125um Single-mode fiber.

This transceiver meets the SFP+ industry standard package utilizing an integral LC-Duplex optical interface connector. An enhanced Digital Diagnostic Monitoring Interface compliant with SFF-8472 has been incorporated into the transceiver. It allows real time access to the transceiver operating parameters such as transceiver temperature, laser bias current, transmitted optical power, received optical power and transceiver supply voltage by reading a built-in memory with I<sup>2</sup>C interface.

The optical output can be disabled by a LVTTTL logic high-level input of Tx Disable, and the system also can disable the module via I<sup>2</sup>C. Tx Fault is provided to indicate that degradation of the laser. Loss of signal (LOS) output is provided to indicate the loss of an input optical signal of receiver or the link status with partner. The system can also get the LOS (or Link)/Disable/Fault information via I<sup>2</sup>C register access.

### 1. Block Diagram

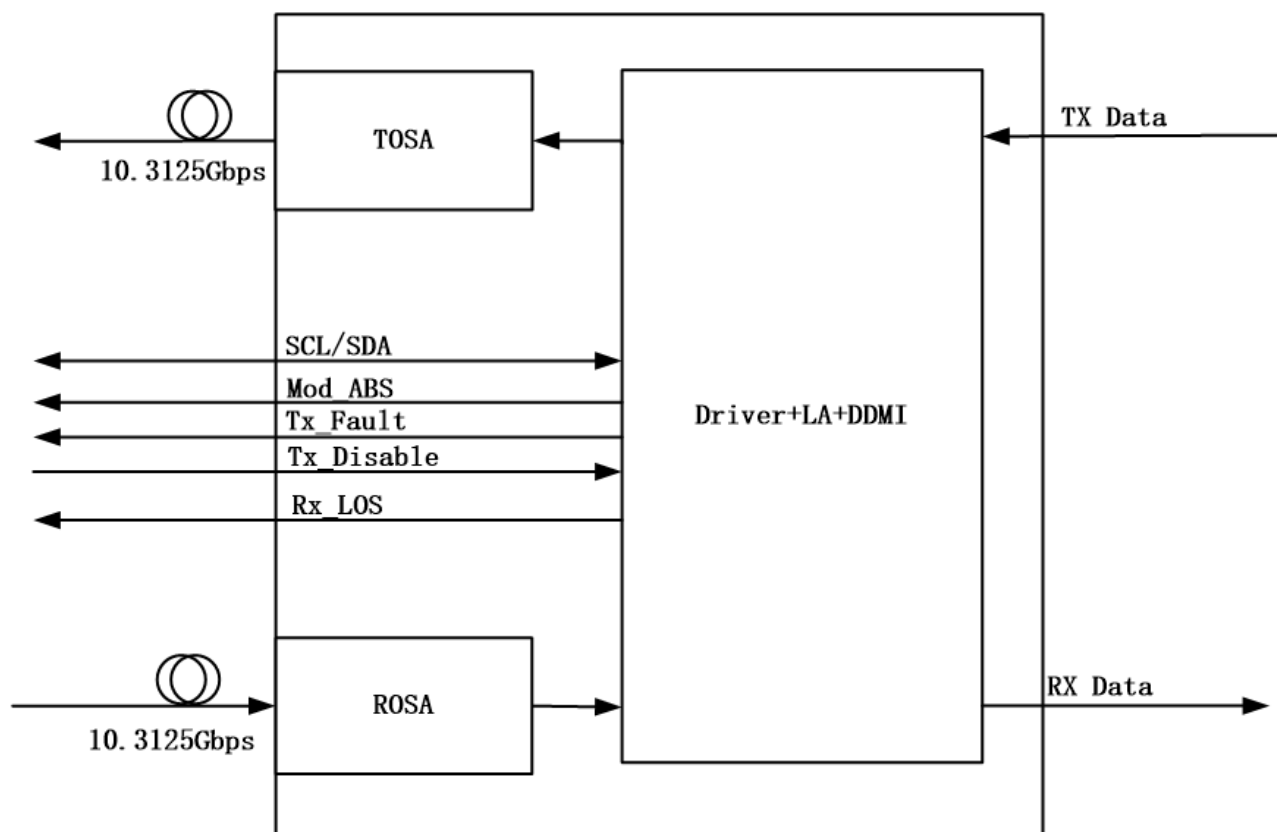

### 2. Pin Diagram

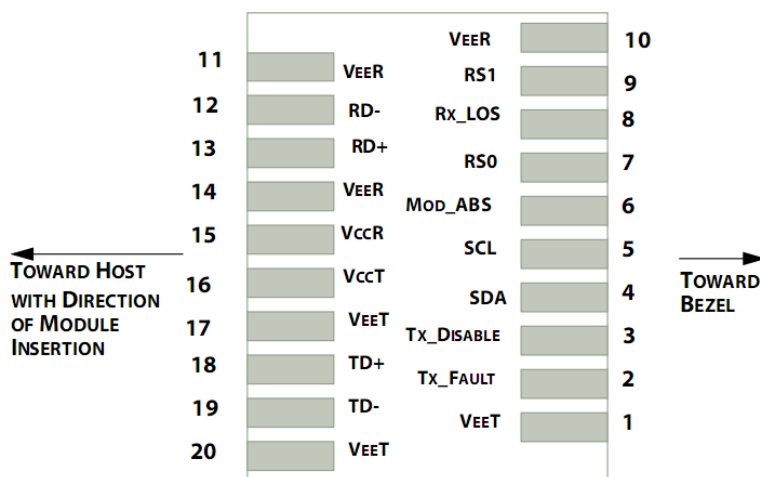

Pin out of Connector Block on Host Board

### 3. Pin Descriptions

Pin	Symbol	Name/Description	Notes
1	V <sub>EET</sub>	Transmitter Ground (Common with Receiver Ground)	1
2	T <sub>FAULT</sub>	Transmitter Fault.	2
3	T <sub>DIS</sub>	Transmitter Disable. Laser output disabled on high or open.	3
4	SDA	2-wire Serial Interface Data Line	4
5	SCL	2-wire Serial Interface Clock Line	4
6	MOD_ABS	Module Absent. Grounded within the module	4
7	RS0	No connection required	
8	LOS	Loss of Signal indication. Logic "0" indicates normal operation.	5
9	RS1	No connection required	
10	V <sub>EER</sub>	Receiver Ground (Common with Transmitter Ground)	1
11	V <sub>EER</sub>	Receiver Ground (Common with Transmitter Ground)	1
12	RD-	Receiver Inverted DATA out. AC Coupled	
13	RD+	Receiver Non-inverted DATA out. AC Coupled	
14	V <sub>EER</sub>	Receiver Ground (Common with Transmitter Ground)	1
15	V <sub>CCR</sub>	Receiver Power Supply	
16	V <sub>CCT</sub>	Transmitter Power Supply	
17	V <sub>EET</sub>	Transmitter Ground (Common with Receiver Ground)	1
18	TD+	Transmitter Non-Inverted DATA in. AC Coupled.	
19	TD-	Transmitter Inverted DATA in. AC Coupled.	
20	V <sub>EET</sub>	Transmitter Ground (Common with Receiver Ground)	1

Notes:

- Circuit ground is internally isolated from chassis ground.
- TX Fault is an open drain output, which should be pulled up with 4.7K ~ 10KΩ resistor on the host board. Pull up voltage between 2.0V to V<sub>cct</sub>/R+0.3V. When high, output indicates a laser fault of some kind. Low indicates normal operation. In the low state, the output will be pulled to < 0.8V. When sensing an improper power level in the laser driver, the SFP sets this signal high and turns off the laser. TX-FAULT can be reset with the TX-DISABLE line. The signal is in LVTTTL level.
- TX disable is an input that is used to shut down the transmitter optical output. It is pulled up within the module with 4.7K ~ 10KΩ resistor. Its states are: Low (0 ~ 0.8V): Transmitter on; (>0.8, < 2.0V):

Undefined; High (2.0V to  $V_{ccT/R}+0.3V$ ): Transmitter Disabled; Open: Transmitter Disabled. The TX-DISABLE signal is high (LVTTL logic “1”) to turn off the laser output. The laser will turn on when TX-DISABLE is low (LVTTL logic “0”).

4. Should be pulled up with 4.7K ~ 10K $\Omega$  on host board to a voltage between 2.0V to  $V_{ccT/R}+0.3V$ . MOD\_ABS pull line low to indicate module is plugged in.
5. LOS (Loss of Signal) is an open collector/drain output, which should be pulled up with 4.7K ~ 10K $\Omega$ resistor. Pull up voltage between 2.0V to  $V_{ccT/R}+0.3V$ . When high, this output indicates the received optical power is below the worst-case receiver sensitivity (as defined by the standard in use). Low indicates normal operation. In the low state, the output will be pulled to < 0.8V.
6. The RX-LOS is high (LVTTL logic “1”) when there is no incoming light from the companion transceiver. This signal is normally used by the system for the diagnostic purpose. The signal is operated in LVTTL level.

#### 4. Absolute Maximum Ratings

It has to be noted that the operation in excess of any individual absolute maximum ratings might cause permanent damage to this module.

Parameter	Symbol	Min	Typ	Max	Unit	Notes
Storage Temperature	$T_s$	-40		85	$^{\circ}C$	
Storage Ambient Humidity	$H_A$	0		85	%	
Power Supply Voltage	$V_{cc}$	-0.5		4	V	
Signal Input Voltage		-0.3		$V_{cc}+0.3$	V	
Receiver Damage Threshold		+3			dBm	
Lead Soldering Temperature/Time	TSOLD			260/10	$^{\circ}C/sec$	1
Lead Soldering Temperature/Time	TSOLD			360/10	$^{\circ}C/sec$	2

Notes:

1. Suitable for wave soldering.
2. Only for soldering by iron.

#### 5. Recommended Operating Conditions

Parameter	Symbol	Min	Typ	Max	Unit	Notes	
Case Operating Temperature	$T_{case}$	0		70	$^{\circ}C$		
		-40		85			
Ambient Humidity	$H_A$	5		85	%	Non-condensing	
Data Rate			10.3125/10.3125		Gb/s	TX Rate/RX Rate	
Transmission Distance				10/20	km		
Coupled Fiber	Single mode fiber						9/125um G.652

#### 6. Electrical Characteristics

Parameter	Symbol	Min	Typ	Max	Unit	Notes
Supply Voltage	$V_{cc}$	3.13	3.30	3.47	V	
<b>Transmitter</b>						

Input different impedance	$R_{in}$	90	100	110	$\Omega$	1
Differential input voltage pk-pk	$V_{pp}$	300		850	mV	
Transmitter Disable Voltage	$V_{DIS}$	2		$V_{CC}$	V	
Transmitter Enable Voltage	$V_{EN}$	0		0.8	V	
<b>Receiver</b>						
Output different impedance	$R_{out}$	90	100	110	$\Omega$	1
Differential output voltage pk-pk	$V_{pp}$	300		850	mV	2
LOS Asserted	$V_{LOSA}$	2		$V_{CC}$	V	3
LOS De-asserted	$V_{LOSD}$	0		0.8	V	3

Notes:

1. Connected directly to TX data input pins. AC coupled thereafter.
2. Into 100 $\Omega$  differential termination.
3. Loss of Signal is LVTTTL. Logic "0" indicates normal operation; logic "1" indicates no signal detected.

## 7. Optical Characteristics

Parameter	Symbol	Min	Typ	Max	Unit	Notes
<b>Transmitter</b>						
Average Output Power	$P_{OUT}$	-8.2		3	dBm	10km
		-5.2		3	dBm	20km
Extinction Ratio	ER	3.5			dB	
Center Wavelength	$\lambda$	1260	1310	1355	nm	DFB Laser
Side Mode Suppression Ratio	SMSR	30			dBm	
Spectrum Width (RMS)	$\sigma$			1	nm	
Transmitter OFF Output Power	$P_{Off}$			-30	dBm	
Output Eye Mask	Compatible with IEEE 802.3ae					
<b>Receiver</b>						
Input Optical Wavelength	$\lambda$	1260		1600	nm	
Rx Sensitivity (OMA)	$R_{SENS1}$			-12.6	dBm	1
Stressed Rx Sensitivity (OMA)	$R_{SENS2}$			-10.3	dBm	2
Input Saturation Power (Overload)	$P_{SAT}$			3	dBm	
Loss of Signal Assert	$P_A$	-30			dBm	
Loss of Signal De-assert	$P_D$			-12.6	dBm	
LOS Hysteresis	$P_D - P_A$	0.5		6	dB	

Notes:

1. Valid between 1260 and 1355nm. Per IEEE 802.3ae.
2. With worst-case extinction ratio. Measured with a PRBS 2<sup>31</sup>-1 test pattern, @10.3125Gb/s, BER<1E-12.

## 8. Digital Diagnostic Monitoring Functions

(IES-)SFP+LX-10(20) support the I2C-based Diagnostic Monitoring Interface (DMI) defined in document SFF-8472. The host can access real-time performance of transmitter and receiver optical power, temperature, supply voltage and bias current.

Parameter	Accuracy	Unit
Case Temperature	±3	°C
Supply Voltage	±3%	V
Tx Bias Current	±10%	mA
Tx Optical Power	±3	dB
Rx Optical Power	±3	dB

## 9. Mechanical Specifications

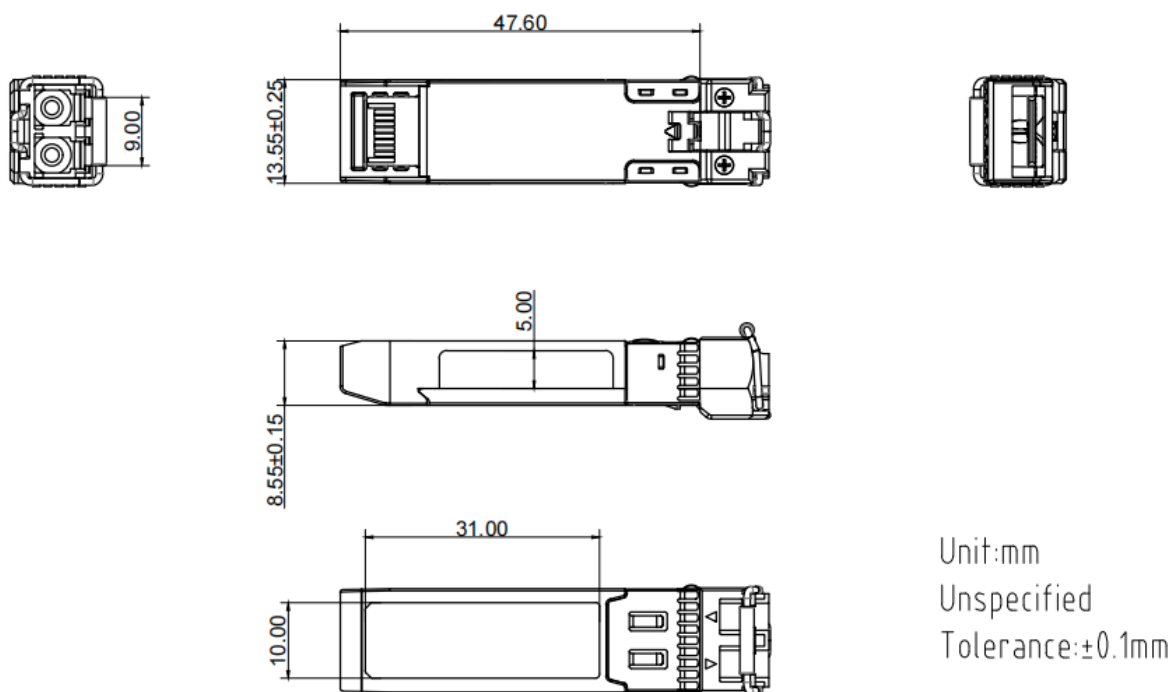

## 10. Regulatory Compliance

Feature	Reference	Performance
EMC	EN61000-3	Compatible with standards
Electrostatic Discharge (ESD)	IEC/EN 61000-4-2	Compatible with standards
Electromagnetic Interference (EMI)	FCC Part 15 Class B EN 55022 Class B (CISPR 22A)	Compatible with standards
Laser Eye Safety	FDA 21CFR 1040.10, 1040.11 IEC/EN 60825-1, EC/EN 60825-2	Class 1 laser product
Component Recognition	IEC/EN 60950, L 60950	Compatible with standards
RoHS 2.0	2002/95/EC	Compatible with standards

## 11. Revision History

Version No.	Date	Description
1.0	June 24, 2019	Preliminary datasheet
1.1	Aug 19, 2021	Added industrial parameters
1.2	Oct. 8,2021	Update contact Information
1.3	Apr.28,2022	Update block diagram
1.4	Jul.27, 2023	Update block diagram, Transmission Distance, Optical Characteristics, Mechanical Specifications